

QDLASER

QLF1335-T200

1310 nm FP LASER TO-CAN

Preliminary

C00110-01 May, 2013



1. DESCRIPTION

The QLF1335-T200 is 1310 nm quantum dot laser diode device for use in extremely high temperature environment. The laser is mounted into a TO-56 header including a monitor PD for optical power control and hermetic sealed with a lens cap. Since quantum dot technologies are equipped with active layers of the device, it realizes excellent temperature characteristics and low power consumptions.

2. FEATURES

- 1310 nm FP-LD
- Temperature insensitive operation
- $\Phi 5.6$ mm TO-CAN package
- Wide temperature operation: -25 to 200deg.C

3. APPLICATION

- High temperature use

4. ABSOLUTE MAXIMUM RATING

($T_c = 25^\circ\text{C}$, unless otherwise specified)

PARAMETER	SYMBOL	RATING	UNIT
Light Output Power	P_o	10	mW
LD Forward Current	I_F	300	mA
LD Reverse Voltage	V_{RLD}	2	V
PD Forward Current	I_{FPD}	2	mA
PD Reverse Current	I_{RPD}	5	mA
PD Reverse Voltage	V_{RPD}	10	V
Operation Temperature (T_c)	T_c	-25 to 200	$^\circ\text{C}$
Storage Temperature	T_{stg}	-40 to 85	$^\circ\text{C}$
Lead Soldering Temperature (5 s)	T_{slid}	230	$^\circ\text{C}$

QDLASER

QLF1335-T200

C00110-01

5. OPTICAL AND ELECTRICAL CHARACTERISTICS

($T_c = 25^\circ\text{C}$, unless otherwise specified)

PARAMETER	SYMBOL	TEST CONDITION	MIN	TYP	MAX	UNIT
Threshold current	I_{th}	CW, 25deg.C	-	15	25	mA
		CW, 200 deg.C	-	70	85	mA
Operation current	I_{op}	CW, $P_o=4$ mW, 25deg.C	-	55	75	mA
		CW, $P_o=2$ mW, 200deg.C	-	120	145	mA
Operation voltage	V_{op}	CW, $P_o=4$ mW	-	1.2	1.6	V
Slope efficiency	η	CW, 25deg.C	0.06	0.10	-	W/A
		CW, 200deg.C	0.02	0.04	-	W/A
Center wavelength	λ_c	CW, $P_o=4$ mW, 25deg.C	1230	1265	1300	nm
Spectral width	$\Delta\lambda$	CW, $P_o=4$ mW, RMS(-20dB), 25deg.C	-	2.5	4	nm
Monitor current	I_m	CW, $P_o=4$ mW, $V_{RD}=5$ V	50	240	1000	μA
Focal length	D_f	CW, $P_o=4$ mW, SI10/125	6.1	7.1	8.1	mm

Notice : Aging test at 200 deg.C is not examined at present.

QDLASER

QLF1335-T200

C00110-01

6. TYPICAL L-I CHARACTERISTICS

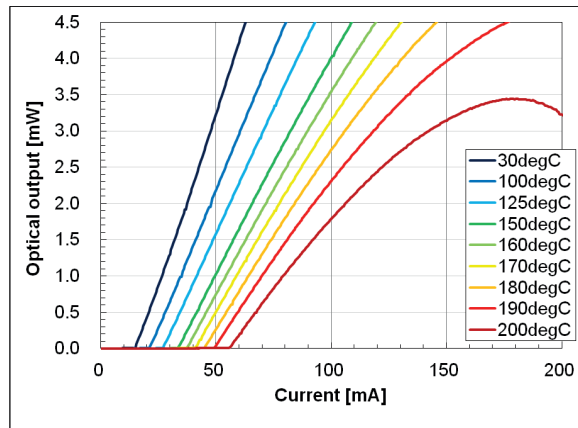

7. OUTLINE DRAWING

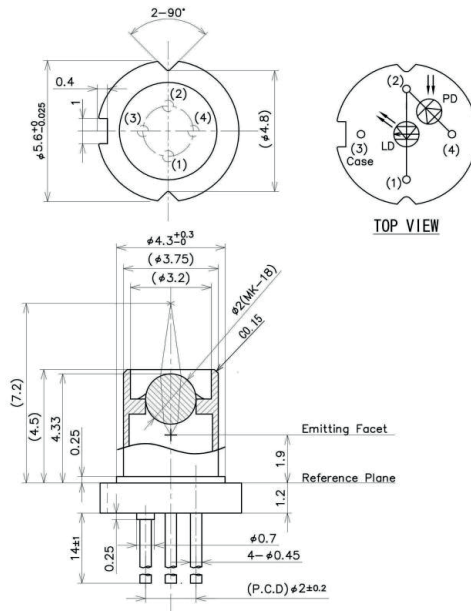

All dimensions in millimeters

Individual. Innovative. Exceptional.

QDLASER

QLF1335-T200

C00110-01

8. NOTICE

- Warrantary period of products

Warrantary period of products is one year from packing date.

- Safety Information

This product is classified as Class 1M laser product, and complies with 21 CFR Part 1040.10.

Please do not take a look laser lighting in operations since laser devices may cause troubles to human eyes.

Please do not eat, burn, break and make chemical process of the products since they contain GaAs material.

- Handling products

Semiconductor lasers are easily damaged by external stress such as excess temperature and ESD.

Please pay attention to handling products, and use within range of maximum ratings.

QD Laser takes no responsibility for any failure or unusual operation resulting from improper handling, or unusual physical or electrical stress.

- RoHS

This product conforms to RoHS compliance related EU Directive 2002/95/EC.

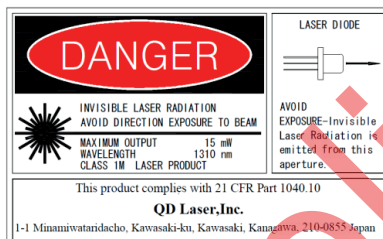

QD Laser, Inc.

Contact : info@qdlaser.com <http://www.qdlaser.com>

Copyright 2013 All Rights Reserved by QD Laser Inc.

Address : Keihin Bldg.1F 1-1 Minamiwataridacho, Kawasaki-ku, Kawasaki, Kanagawa Zip 210-0855 Japan

All company or product names mentioned herein are trademarks or registered trademarks of their respective owners. Information provided in this data sheet is accurate at time of publication and is subject to change without advance notice.