

QDLASER

QLF063A-4080T30

640 nm 80mW FPLASER TO-CAN, Anode common type, Tc=30deg.C

C00127-02 March 2015



1. DESCRIPTION

The QLF063A-4080T30 is a 640 nm quantum well laser device designed for visible laser application. The laser diode is mounted into a TO-56 header including a monitor PD and hermetic sealed with a flat glass cap.

2. FEATURES

- 640 nm FP-LD
- Operating temperature range=-10 to 30deg.C
- Φ 5.6mm TO-CAN package
- Including monitor PD
- Anode common type

3. APPLICATIONS

- Industrial laser markers
- Measuring instruments

4. ABSOLUTE MAXIMUM RATING

(CW operation, $T_c = 25^\circ\text{C}$, unless otherwise specified)

PARAMETER	SYMBOL	RATING	UNIT
Optical output power	$P_o(\text{CW})$	90	mW
LD reverse voltage	V_{RLD}	2	V
PD reverse voltage	V_{RPD}	30	V
Operation temperature	T_c	-10 to 30	$^\circ\text{C}$
Storage temperature	T_{stg}	-40 to 85	$^\circ\text{C}$

Distributed by



Ohmstrasse 4 85716 Unterschleissheim Germany
Tel.: +49 89 / 3214120 Fax: +49 89 / 32141211

www.imm-photonics.de
sales@imm-photonics.de

5. OPTICAL AND ELECTRICAL CHARACTERISTICS

($T_c = 25^\circ\text{C}$, unless otherwise specified)

PARAMETER	SYMBOL	TEST CONDITION	MIN	TYP	MAX	UNIT
Threshold current	I_{th}	CW	-	60	100	mA
Operation current	$I_{op}(CW)$	CW, $P_o=80\text{mW}$	-	135	160	mA
Operation voltage	V_{op}	CW, $P_o=80\text{mW}$	-	2.4	3.2	V
Slope efficiency	η	CW, $P_o=5 - 80\text{mW}$	0.8	1.0	-	W/A
Monitor current	I_m	CW, $P_o=80\text{mW}$, $V_{RD}=5\text{ V}$	400	1000	1800	μA
Peak wavelength	λ_p	CW, $P_o=80\text{mW}$	635	641	650	nm
Far filed pattern horizontal	θ_h	CW, $P_o=80\text{mW}$	4	7	13	deg.
Far filed pattern vertical	θ_v	CW, $P_o=80\text{mW}$	11	15	22	deg.
Beam angle Horizontal	$d\theta_h$	CW, $P_o=80\text{ mW}$	-3	-	3	deg.
Beam angle vertical	$d\theta_v$	CW, $P_o=80\text{ mW}$	-3	-	3	deg.

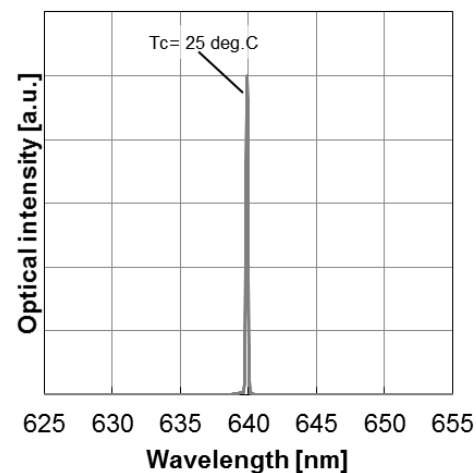
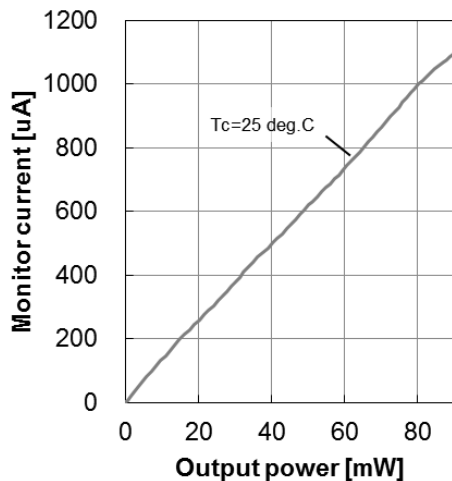
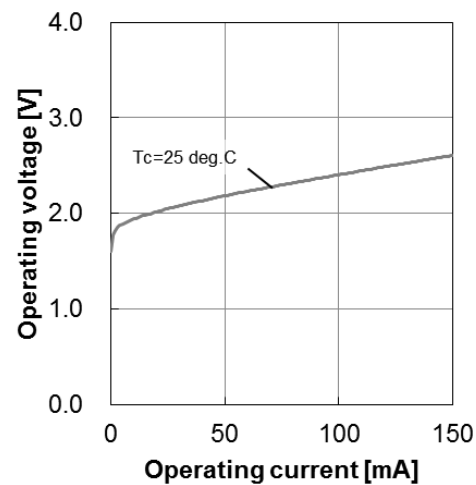
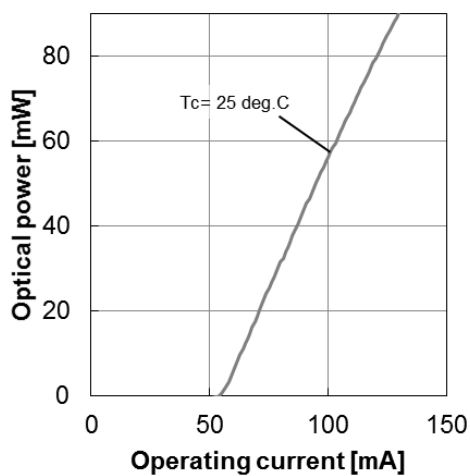

6. Outline Drawing

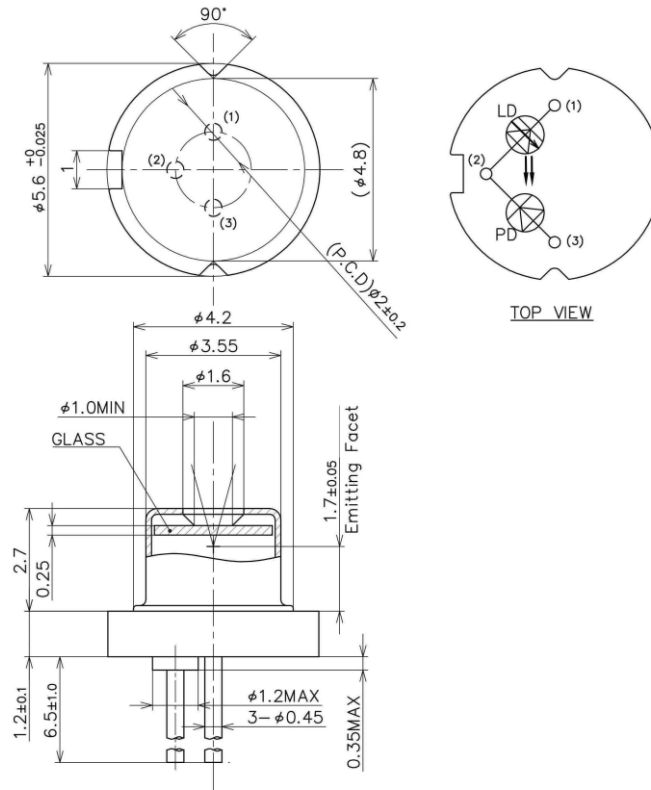

Notes.
 1. All dimensions in millimeters
 2. Unless otherwise specified, Tolerance $\pm 0.3\text{mm}$

Notice

- Safety Information

This product is classified as Class 3B laser product, and complies with 21 CFR Part 1040.10. Please do not take a look laser lighting in operations since laser devices may cause troubles to human eyes. Please do not eat, burn, break and make chemical process of the products since they contain GaAs material.

- Handling products

Semiconductor lasers are easily damaged by external stress such as excess temperature and ESD. Please pay attention to handling products, and use within range of maximum ratings. QD Laser takes no responsibility for any failure or unusual operation resulting from improper handling, or unusual physical or electrical stress.

- RoHS

This product conforms to RoHS compliance related EU Directive 2011/65/EU.

QD Laser, Inc.

Contact : info@qdlaser.com <http://www.qdlaser.com>

Copyright 2014-2015 All Rights Reserved by QD Laser Inc.

Address : Keihin Bldg.1F 1-1 Minamiwataridacho, Kawasaki-ku, Kawasaki, Kanagawa Zip 210-0855 Japan

All company or product names mentioned herein are trademarks or registered trademarks of their respective owners. Information provided in this data sheet is accurate at time of publication and is subject to change without advance notice.

Distributed by  IMM photonics

Ohmstrasse 4 85716 Unterschleissheim Germany
 Tel.: +49 89 / 3214120 Fax: +49 89 / 32141211

www.imm-photonics.de
sales@imm-photonics.de