

IMM PHOTONICS – OPTOELECTRONIC COMPONENTS

engineered for your success

ilumCURE 1G



ilumCURE 2G



Variolenses



OUR PRODUCT GROUPS



MAXIMUM PRECISION – FROM STANDARD TO INDIVIDUALLY DEVELOPED PRODUCTS

IMM Photonics produces innovative optical and optoelectronic components and modules for a diverse range of technological fields – from measuring technology and analytics, biophotonics and medical devices to optical data transfer and security engineering.

What makes our portfolio special: Our **standard products** in laser technology, fibre optics, UV & UVC and optics can be refined on request and tailored to the customer's specific needs. We also produce complete **individual solutions** to meet our customers' budgets and deadlines as well as the high quality standards they demand. Both types of product can be easily integrated into existing customer systems.

IMM PHOTONICS – EXPERTISE SINCE 1992

With our well established presence on the market, for more than 30 years we at IMM Photonics have provided trust-based and successful support to customers from a range of technological fields with the production of innovative components and modules. Our standard optical and optoelectronic products are produced in-house at our two German business locations and by selected partner manufacturers – for truly high-tech products made in Germany.

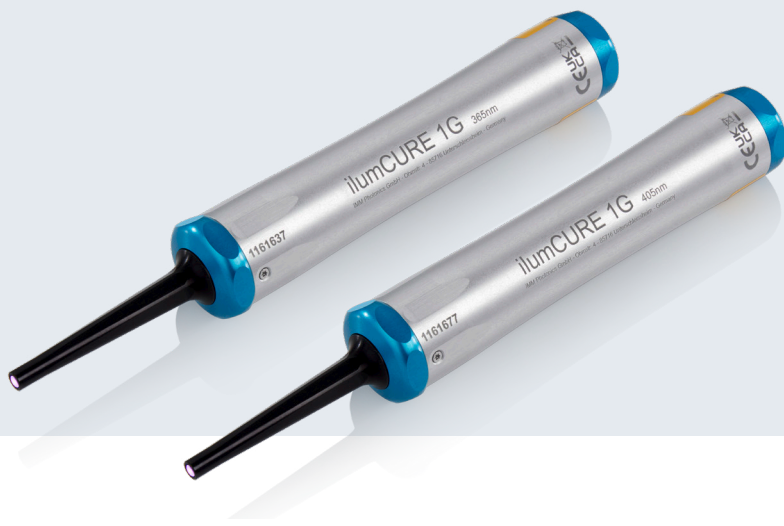

ilumCURE 1G

The UV handheld lighting device ilumCURE 1G by IMM Photonics is an UV light source with a central wavelength of 365 nm or 405 nm. It serves as mobile UV light source for the curing of UV adhesives.

The ilumCURE 1G features a robust aluminium housing and was especially developed for fieldwork. The integrated lithium ion battery allows up to 3 hours of continuous operation. The ilum-CURE 1G can be re-charged (standard charge) with various USB Ports. With a mains adaptor (separately sold or included) you can fast charge and / or directly operate the device via an AC power outlet.

Thanks to the high-performance UV LED, the curing of UV adhesives requires only a few seconds of exposure.

Wavelength	365 nm		405 nm	
Art. No.	1600000038	1600000041	1600000065	1600000066
Output	250 mW (typ.)		290 mW (typ.)	
Packaging	systainer	quadrosafe	systainer	quadrosafe
Start-up	Via push-button on housing			
Battery	Li-ion / 3.6 V, 2250 mAh, exchangeable			
Battery safety functions	Over- and undervoltage, overcurrent, excess temperature			
Charging time for completely discharged battery	< 4.0 h fast charge < 5.5 h standard charge			
Operating time with fully charged battery	3.0 hours			
Fast charge	Automatically detected			
Chargers	Fast charge: USB mains adaptor 5 V / 1000 mA Standard charge: various USB mains adaptors, PC			
Charging indicator (next to USB-B port)	Red: Charging in progress Green: Battery is fully charged			
Overall Dimensions	Length 185 mm, max. diameter 27.5 mm			
Lighting tip dimensions	Total length of tip 53 mm, diameter 5 mm (along 8 mm)			
Weight / Material	Approx. 100 g / full metal housing, anodised aluminium			
Operating / storage temperature	+5 °C to +45 °C / -10 °C to +70 °C			
Humidity	5 % to 95 % r. h. (non-condensing)			
Delivery	<ul style="list-style-type: none"> ilumCURE 1G Systainer (W 26.5 cm, D 17.0 cm, H 7.5 cm) Adaptor (USB 5 V / 1000 mA), Cable USB-A / USB-B Instruction manual 	<ul style="list-style-type: none"> ilumCURE 1G Quadrosafe (L 19 cm, D 4.5 cm, PP, transparent) Cable USB-A to USB-B Instruction manual 	<ul style="list-style-type: none"> ilumCURE 1G Systainer (W 26.5 cm, D 17.0 cm, H 7.5 cm) Adaptor (USB 5 V / 1000 mA) Cable USB-A / USB-B Instruction manual 	<ul style="list-style-type: none"> ilumCURE 1G Quadrosafe (L 19 cm, D 4.5 cm, PP, transparent) Cable USB-A to USB-B Instruction manual
Available accessories	<ul style="list-style-type: none"> Variable collimating lens W (Art. No. 1600000064) Variable collimating lens N (Art. No. 1600000071) 	<ul style="list-style-type: none"> Fast charge USB mains adaptor (Art. No. 1600000100) Variable collimating lens W (Art. No. 1600000064) Variable collimating lens N (Art. No. 1600000071) 	<ul style="list-style-type: none"> Variable collimating lens W (Art. No. 1600000064) Variable collimating lens N (Art. No. 1600000071) 	<ul style="list-style-type: none"> Fast charge USB mains adaptor (Art. No. 1600000100) Variable collimating lens W (Art. No. 1600000064) Variable collimating lens N (Art. No. 1600000071)

Subject to technical modifications. As per April 2022.

PACKAGING



Systemer

Dimensions W 26.5 cm, D 17.0 cm, H 7.5 cm

With the separately sold USB mains adaptor you can fast charge and / or directly operate the device via an AC power outlet.

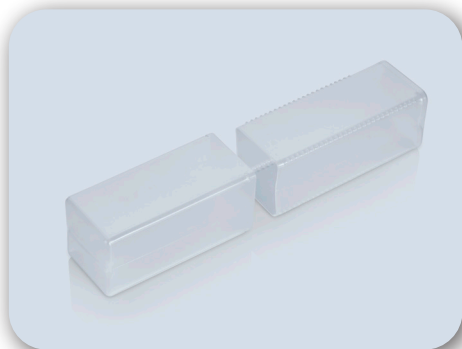

Quadrosafe

Dimensions: L 19 cm, D 4.5 cm, PP, transparent

With the separately sold mains adaptor you can fast charge and / or directly operate the device via an AC power outlet.



illumCURE 2G

illumCURE 2G is a UV LED illumination system for hardening UV adhesives reproducibly at high intensities with a peak intensity wavelength of 365 nm or 405 nm.

The device facilitates continuous illumination as well as timer- and interface-controlled illumination with an adjustable intensity. It can be employed for both mobile and stationary applications (e.g. in automated production). For mobile usage, the built-in lithium-ion battery permits a continuous operation of up to 3.5 hours at full intensity. The USB interface is used for charging, parameterisation and process automation.

Reproducible hardening processes are ensured in real time by a controller-operated LED current measurement as well as by a heat management system with metal core technology. A robust aluminium housing and an exchangeable battery ensure the longevity of the product.

Wavelength	365 nm	365 nm	405 nm	405 nm
Art. No.	1600000053	1600000067	1600000090	1600000089
Packaging	systainer	quadrosafe	systainer	quadrosafe
LED				
UVA Power	250 mW (typ.) at 100 % adjusted intensity		290 mW (typ.) at 100 % adjusted intensity	
Lifetime	7000 h at 80 % UV LED emission			
Setting options / operation				
Trigger illumination	Via push-button on housing and USB			
Illumination time	Timer enabled: 1.0 s – 120.0 s, resolution 0.1 s Timer disabled: limited by protection features only			
Intensity	10 % - 100 %, CW-dimmed, 10 % resolution			
Timer	Can be switched on and off			
Beep signal	Can be switched on and off			
Programming on hand set	Can be switched on and off			
Software				
Supported Windows versions	XP (32 bit), 7 (32 and 64 bit), 8 (32 and 64 bit), 10 (32 and 64 bit), 11 (32 and 64 bit)			
Max. number of devices per PC	127			



Wavelength	365 nm	365 nm	405 nm	405 nm
Art. No.	1600000053	1600000067	1600000090	1600000089

Power management

Battery Li-Ion / 3.6 V, 2250 mAh, exchangeable

Operating time when battery is fully discharged < 4.0 hours fast charge, < 5.5 hours standard charge

Operating time when battery is fully charged 3.5 hours

Fast charged Automatically detected

Chargers Fast charge: USB mains adaptor 5 V / 1000 mA
Standard charge: PC, various USB mains adaptors

Charge indicator (next to USB-B port) Blinking red: fast charge
Red: standard charge / Green: battery is fully charged

Protection features

Battery Overvoltage and undervoltage, overcurrent, excess temperature

UV LED excess temperature Switch-off at LED temperature > 50 °C

LED current Intensity 10 % - 30 %: Switch-off if nominal current value is exceeded by ±15 %
Intensity 40 % - 100 %: Switch-off if nominal current value is exceeded by ±5 %

Error indication Blinking orange for 10 s, beeping: LED current error
Blinking orange, beeping as long as UV LED too hot: excess temperature

General information

Total device dimensions Length 185 mm, max. diameter 27.5 mm

Lighting tip dimensions Total length of tip 53 mm, diameter 5 mm (along 8 mm)

Weight / material Approx. 108 g / full-metal housing, anodised aluminium

Operating / storage temperature +5 °C to +45 °C / -10 °C to +70 °C

Humidity 5 % to 95 % r. h. (non-condensing)

Included in delivery scope	<ul style="list-style-type: none"> • Systainer • USB-A to USB-B cable • Fast charge mains adaptor • USB flash drive with software 	<ul style="list-style-type: none"> • USB-A to USB-B cable • USB flash drive with software 	<ul style="list-style-type: none"> • Systainer • USB-A to USB-B cable • Fast charge mains adaptor • USB flash drive with software 	<ul style="list-style-type: none"> • USB-A to USB-B cable • USB flash drive with software
-----------------------------------	---	---	---	---

Available accessories	<ul style="list-style-type: none"> • Variable collimating lens W (Art. No. 1600000064) • Variable collimating lens N (Art. No. 1600000071) 	<ul style="list-style-type: none"> • Fast charge USB mains adaptor (Art. No. 1600000100) • Variable collimating lens W (Art. No. 1600000064) • Variable collimating lens N (Art. No. 1600000071) 	<ul style="list-style-type: none"> • Variable collimating lens W (Art. No. 1600000064) • Variable collimating lens N (Art. No. 1600000071) 	<ul style="list-style-type: none"> • Fast charge USB mains adaptor (Art. No. 1600000100) • Variable collimating lens W (Art. No. 1600000064) • Variable collimating lens N (Art. No. 1600000071)
------------------------------	--	---	--	---

Subject to technical modifications. As per April 2022.

SETTING OPTIONS / OPERATION

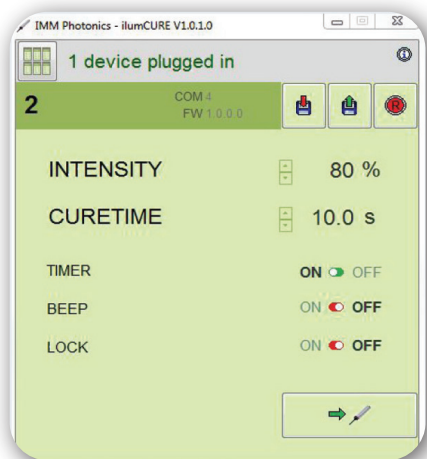

Via Software:

- Intensity from 10 % to 100 %
- Cure time from 1.0 s to 120.0 s
- Illumination timer on or off
- Beep signal at the end of illumination period on or off
- Time programming on hand set locked or allowed

Via hand set:

- Illumination time from 1.0 s to 120.0 s
- Trigger illumination

PROCESS AUTOMATION

- Using a permanent USB connection illumCURE 2G devices can be controlled remotely from the PC
- A Software Development Kit for the integration into proprietary code (such as Labview, C#) is available
- Major functionalities: illumination on/off, intensity profiles, status requests, up to 127 devices per PC

Variolens N / Variolens W



The vario lens N and vario lens W are available as accessories to be fitted to the ilumCURE series of exposure units in order to homogenously and efficiently cure larger surfaces to which adhesive has been applied.

	Variolens N	Variolens W
Art. No.	160000071	160000064
Typical max. optical output power*2 of ilumCURE 1G, ilumCURE 2G*1 or ilumCURE industrial*1 with Variolens N	100 mW @ 365 nm	
Typical max. optical output power*2 of ilumCURE 1G, ilumCURE 2G*1 or ilumCURE industrial*1 with Variolens W	200 mW @ 365 nm	
Typical optical power density*3 of ilumCURE 1G, ilumCURE 2G*1 or ilumCURE industrial*1 with Variolens N	95 mW/cm ² @ 0 mm distance 110 mW/cm ² @ 5 mm distance 135 mW/cm ² @ 10 mm distance 150 mW/cm ² @ 15 mm distance 157 mW/cm ² @ 20 mm distance 160 mW/cm ² @ 25 mm distance 157 mW/cm ² @ 30 mm distance 140 mW/cm ² @ 40 mm distance 95 mW/cm ² @ 50 mm distance 50 mW/cm ² @ 75 mm distance 28 mW/cm ² @ 100 mm distance 18 mW/cm ² @ 125 mm distance 13 mW/cm ² @ 150 mm distance	
Typical optical power density*4 of ilumCURE 1G, ilumCURE 2G*1 or ilumCURE industrial*1 with Variolens W		183 mW/cm ² @ 0 mm distance 222 mW/cm ² @ 5 mm distance 243 mW/cm ² @ 10 mm distance 247 mW/cm ² @ 15 mm distance 220 mW/cm ² @ 20 mm distance 180 mW/cm ² @ 25 mm distance 140 mW/cm ² @ 30 mm distance 90 mW/cm ² @ 40 mm distance 60 mW/cm ² @ 50 mm distance 26 mW/cm ² @ 75 mm distance 13 mW/cm ² @ 100 mm distance 8,5 mW/cm ² @ 125 mm distance 6 mW/cm ² @ 150 mm distance
Illuminated area	6 mm x 6 mm @ 25 mm distance 9 mm x 9 mm @ 50 mm distance 13,5 mm x 13,5 mm @ 75 mm distance 20,0 mm x 20,0 mm @ 100 mm distance 24,5 mm x 24,5 mm @ 125 mm distance 27,5 mm x 27,5 mm @ 150 mm distance	8 mm x 8 mm @ 25 mm distance 12,5 mm x 12,5 mm @ 50 mm distance 22 mm x 22 mm @ 75 mm distance 32 mm x 32 mm @ 100 mm distance 41 mm x 41 mm @ 125 mm distance 50 mm x 50 mm @ 150 mm distance
Homogeneity within illuminated area	> 90 %	
Working distance	Unlimited	
Focal distance	25 mm to 125 mm	50 mm to 150 mm
Focusing	By rotating the lens holder	
Adjustment range of the lens holder	3 mm	
Weight / material	Approx. 8 g / glas, anodised aluminium	

Art. No.	Variolens N	Variolens W
	1600000071	1600000064
Dimensions	Total length: 33 mm, diameter 18 mm	
Total dimensions ilumCURE 1G and ilumCURE 2G	Length: max. 157 mm Diameter: max. 27.5 mm	
Total dimensions ilumCURE industrial	Length: max. 157 mm Diameter: max. 25 mm	
Operating / storage temperature	+5 °C to +45 °C / -10 °C to +70 °C	
Humidity	5 % to 95 % r. h. (non-condensing)	
Included accessories	Hexagon wrench (size 0.9 mm) for locking the lens holder	

*1 Operated at 100 % intensity

*2 Measured with Optometer Gigahertz P9710 and Ulbricht Sphere ISD-5P-SiUV-2

*3 Measured with Hoenle UV-Meter µC Basic 16501 and Detector Head 16401/UV-AD1 E110

*4 Measured with EIT SPOTCURE UV Intensity Meter SP365

Subject to technical modifications. As per April 2022.

SAFETY MEASURES AND WARNINGS

- Comply with safety regulations according to currently valid standards! (2006/25/EC, DIN EN 62471-2009, etc.)
- Do not stare directly into the light source. Ultra violet or visible radiation can permanently damage the eyes!
- Take precautions; use protective window or eye protection made of suitable materials!
- Always avoid exposure to skin and eyes!
- Avoid humidity! (excessive air moisture > 95% r. h., splash water, direct immersion in water)
- Do not expose the UV light source to excessive temperatures! (see specifications)
- Operation only by trained personnel! (keep away from children)
- Device contains glass components, so protect from vibrations!

USAGE

The Variolens N and Variolens W is attached on the handheld light sources of ilumCURE family to harden wide areas of adhesives homogeneously and fast.

PROPERTIES

By rotating the lens holder the nearly square shaped exposure window is focused in a working distance from approx. 25 mm to 125 mm (Variolens N) / approx. 50 mm to 150 mm (Variolens W). By tightening the screw, the lens holder can be secured against further rotation.



HOW TO MOUNT THE VARIOLENS N ON THE ILUMCURE DEVICES

1. Remove the standard lighting tip of the ilumCURE by carefully pulling towards the front.
2. **ilumCURE 1G / ilumCURE 2G Series:** Plug the adaptor of the Variolens into the receptacle of the ilumCURE (flattened side is facing upward directing to the push button, see picture) until it snaps into place.

ilumCURE industrial series: Plug the adaptor of the Variolens into the receptacle of the ilumCURE (flattened side is facing upward directing to the push button, see picture) and tighten the screw in the ilumCURE-housing (size hexagon wrench 1.5 mm).

3. By rotating the lens holder the illuminated area can be focused on the desired working distance and locked. If required it can be locked in this position by using the supplied Allen key.



OPERATION

- | | |
|------------------------------------|--|
| ilumCURE 1G series: | Operated by the push button of the handheld light source |
| ilumCURE 2G series: | Operated by the push button of the handheld light source or via Software |
| ilumCURE industrial series: | Operated via Software only |

CLEANING

If necessary, the Variolens can be cleaned carefully with a soft lint-free cloth (such as a lens cleaning cloth). Don't use aggressive or abrasive cleansing agents or detergents!

MAINTENANCE

The device is generally maintenance-free. Please avoid fingerprints on the glass surface! If the Variolens is quite dirty (e.g. hardened adhesive residues) it should be replaced by a new one. Otherwise the homogeneity of the beam is no longer warranted.

ILLUMINATED AREA VS. WORKING DISTANCE

Variolens N

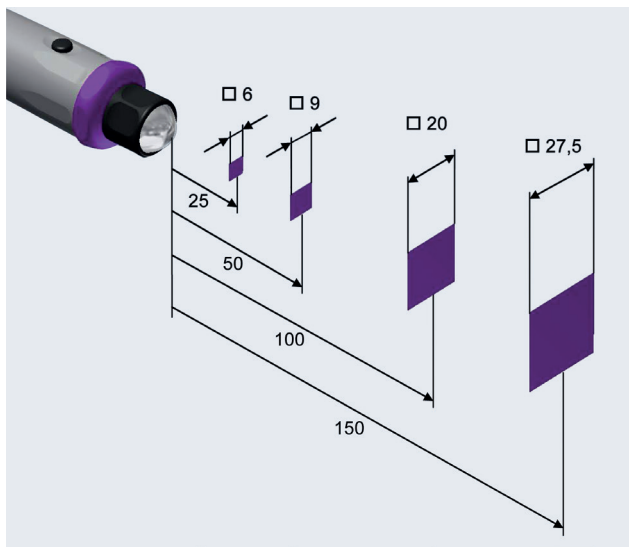

Variolens W

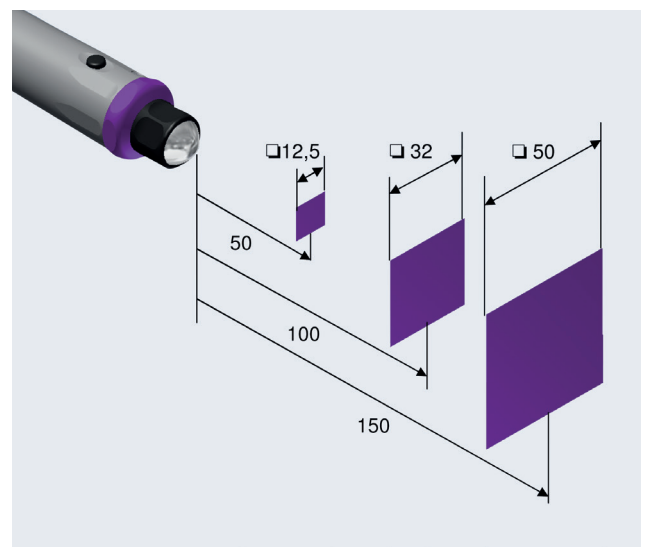

BEAM PROFILES

Variolens N

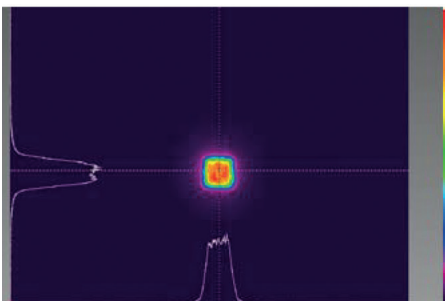

Beam profile at a distance of 25 mm

Variolens W

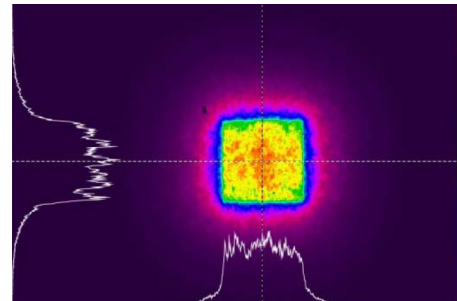

Beam profile at a distance of 50 mm

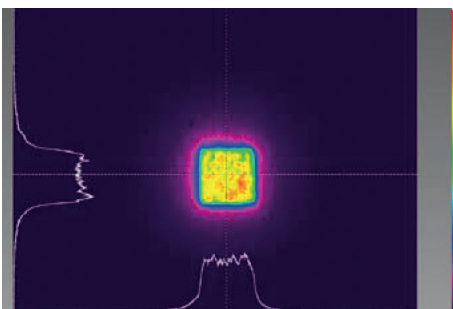

Beam profile at a distance of 50 mm

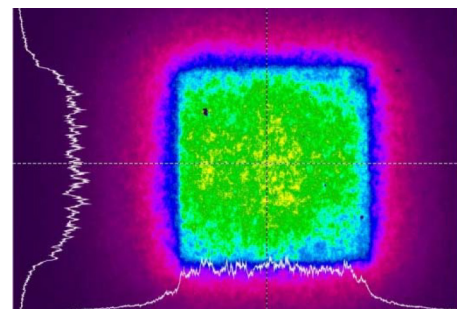

Beam profile at a distance of 100 mm

Variolens N

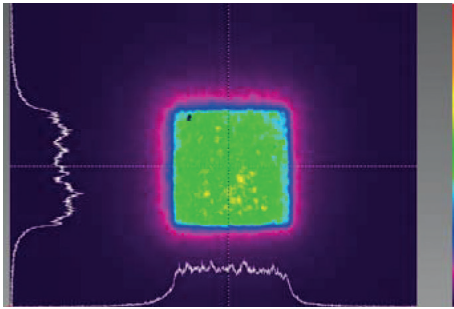

Beam profile at a distance of 125 mm

Variolens W

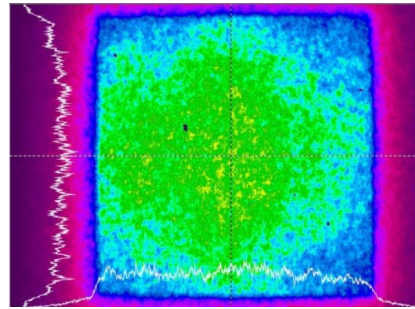

Beam profile at a distance of 150 mm

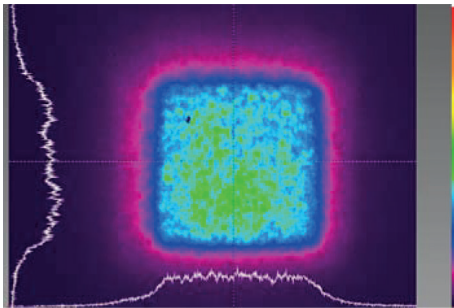

Beam profile at a distance of 150 mm

EXPERIENCE MEETS EXPERTISE IN INNOVATION

We have been developing, manufacturing and distributing optical and optoelectronic standard products and individual solutions for more than 30 years, working as a reliable and capable partner with customers from many industrial sectors. Need someone you can trust with a complex task? The full extent of our experience and expertise in innovation is at your disposal. We look forward to developing prototypes and batch products for you at our two production sites in Germany – in keeping with the highest technical standards and with outstanding support from our large network of partners.

You get the **benefit** of advice, development and manufacturing all from a single source, designed and made in Germany.



imm-photonics.de

IMM Photonics GmbH

Ohmstrasse 4

85716 Unterschleissheim, Germany

Phone: +49 89 32 14 12-43

sales@imm-photonics.de