

# QDLASER

## QLD1061-3030 series

1030 nm DFB Laser Butterfly Package

Preliminary

C00095-03 March 2015



### 1. DESCRIPTION

The QLD1061-3030 is a 1030-nm distributed feedback (DFB) laser for use in seeder for fiber lasers and sensing applications. The laser is assembled into a 14-pin butterfly package with an optical isolator, a monitor PD and a thermo-electric cooler.

### 2. FEATURES

- Single longitudinal mode operation at 1030 nm
- Fiber-pigtailed 14-pin butterfly package with a TEC
- Optical isolator integration
- Polarization maintaining fiber integration
- CW/Pulse operation

### 3. APPLICATION

- Seeder for fiber lasers
- Sensing

### 4. ABSOLUTE MAXIMUM RATING

PARAMETER	SYMBOL	RATING	UNIT
Optical Output power	$P_f$	50	mW
LD Forward Current	$I_f$	250	mA
LD Reverse Voltage	$V_{RLD}$	2	V
TEC Drive Current	$I_{TEC}$	2	A
TEC Drive Voltage	$V_{TEC}$	4.3	V
Operation Temperature	$T_c$	0 to 60	°C
Storage Temperature	$T_{stg}$	-40 to 85	°C
Lead Soldering Temperature (5 s)	$T_{sld}$	230	°C

Distributed by  imm photonics

Ohmstrasse 4, 85716 Unterschleissheim, Germany

www.imm-photonics.de sales@imm-photonics.de Tel.: +49 89 / 3214120

## 5. OPTICAL AND ELECTRICAL CHARACTERISTICS

( $T_{LD} = 25^{\circ}\text{C}$ , unless otherwise specified)

PARAMETER	SYMBOL	TEST CONDITION	MIN	TYP	MAX	UNIT
Peak Wavelength	$\lambda_p$	CW, $P_f=30$ mW	1025*	1030	1035*	nm
Temperature Coefficient of $\lambda_p$	$d\lambda_p/dT$	CW	-	0.08	-	nm/K
Current Coefficient of $\lambda_p$	$d\lambda_p/dI$	CW	-	0.01	-	nm/mA
Fiber Output Power	$P_f$	CW	30	-	-	mW
Threshold Current	$I_{th}$	CW	-	20	-	mA
Operation Current	$I_{op}$	CW, $P_f=30$ mW	-	150	200	mA
Operation Voltage	$V_{op}$	CW, $P_f=30$ mW	-	1.7	2.0	V
Sidemode Suppression Ratio	SMSR	CW, $P_f=30$ mW	-	40	-	dB
Polarization Extinction Ratio	PER	CW, $P_f=30$ mW	15	20	-	dB
Monitor PD Current	$I_m$	CW, $P_f=30$ mW	50	100	1000	$\mu\text{A}$
Thermistor Resistance	$R_{th}$	$T_{LD} = 25^{\circ}\text{C}$ , $B=3900\text{K}$	9.5	10	10.5	$\text{k}\Omega$

\*Peak wavelength tolerance of +/- 1nm is available as an option.

## 6. PRODUCT PART NUMBER

Part Number	Fiber Type	Fiber Diameter	Connector
QLD1061-3030	Polarization maintaining fiber	900um	FC/APC
QLD1061-3030-11		250um	Ferrule

## 7. OUTLINE DRAWING

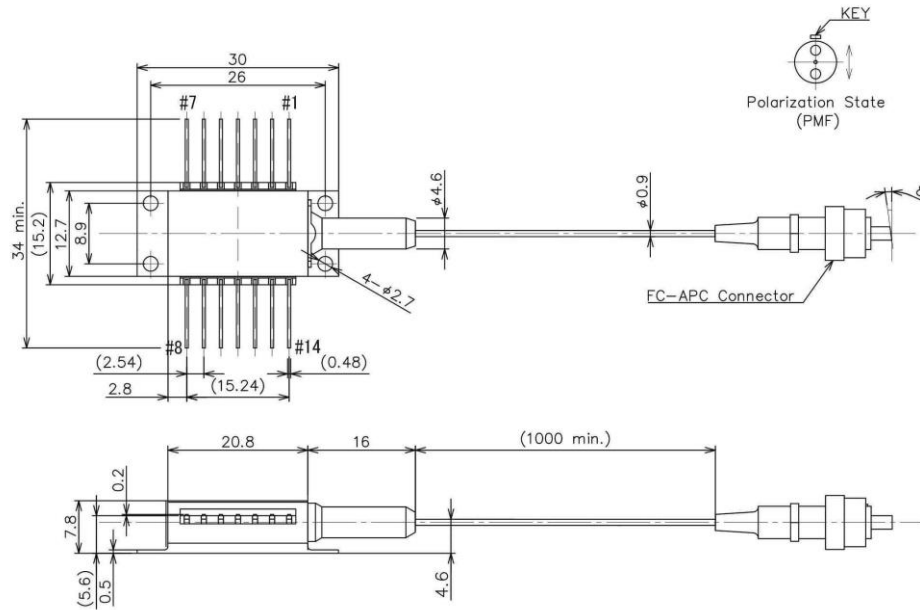

(a) 900um fiber diameter and FC/APC connector type (QLD1061-3030)

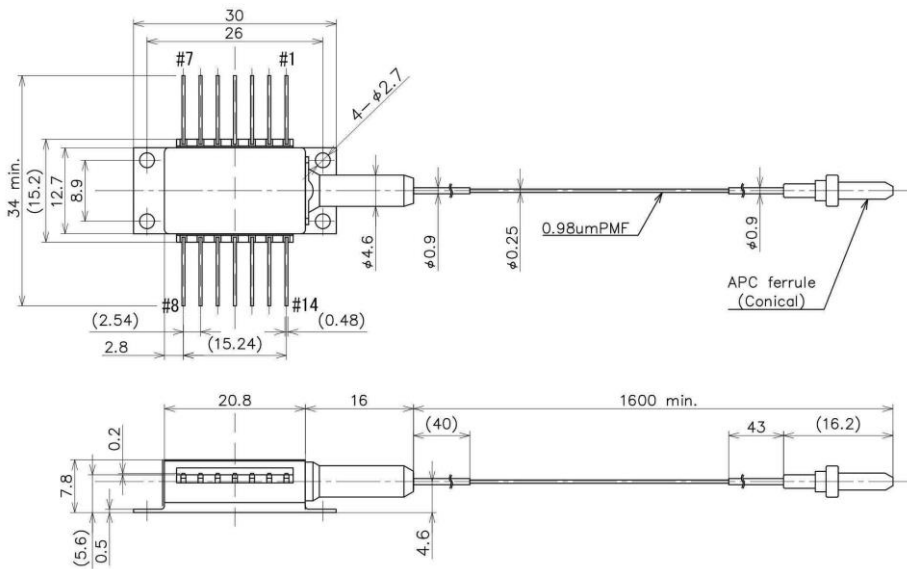

(b) 250um fiber diameter and ferrule type (QLD1061-3030-11)

## 8. PIN CONFIGURATION

No.	Description	No.	Description
1	TEC (+)	8	NC
2	Thermistor	9	NC
3	PD Anode	10	Laser Anode
4	PD Cathode	11	Laser Cathode
5	Thermistor	12	NC
6	NC	13	Case Ground
7	NC	14	TEC (-)

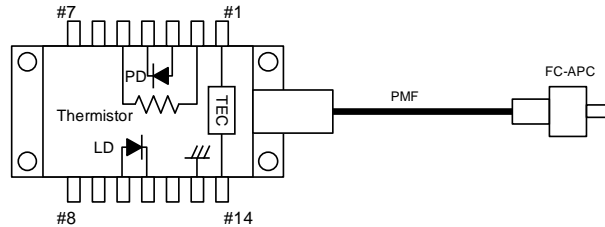

## 9. NOTICE

- Safety Information

This product is classified as Class 3B laser product, and complies with 21 CFR Part 1040.10.

Please do not take a look at laser lighting in operations since laser devices may cause troubles to human eyes.

Please do not eat, burn, break and make chemical process of the products since they contain GaAs material.

- Handling products

Semiconductor lasers are easily damaged by external stress such as excess temperature and ESD.

Please pay attention to handling products, and use within range of maximum ratings.

QD Laser takes no responsibility for any failure or unusual operation resulting from improper handling, or unusual physical or electrical stress.

- RoHS

This product conforms to RoHS compliance related EU Directive 2011/65/EU.

<p><b>DANGER</b></p> <p>INVISIBLE LASER RADIATION AVOID DIRECTION EXPOSURE TO BEAM</p> <p>MAXIMUM OUTPUT 300 mW WAVELENGTH 1000~1200 nm CLASS 3B LASER PRODUCT</p>	<p>LASER DIODE</p> <p>AVOID EXPOSURE-Invisible Laser Radiation is emitted from this aperture.</p>
<p>This product complies with 21 CFR Part 1040.10</p> <p><b>QD Laser, Inc.</b></p> <p>1-1 Minamiwataridacho, Kawasaki-ku, Kawasaki, Kanagawa, 210-0855 Japan</p>	

Distributed by **imm photonics**

Ohmstrasse 4, 85716 Unterschleissheim, Germany

www.imm-photonics.de sales@imm-photonics.de Tel.: +49 89 / 3214120

**QD Laser, Inc.**

Contact : [info@qdlaser.com](mailto:info@qdlaser.com) <http://www.qdlaser.com>

Copyright 2012-2015 All Rights Reserved by QD Laser, Inc.

Keihin Bldg. 1F 1-1 Minamiwatarida-cho, Kawasaki-ku, Kawasaki, Kanagawa Zip 210-0855 Japan

All company or product names mentioned herein are trademarks or registered trademarks of their respective owners. Information provided in this data sheet is accurate at time of publication and is subject to change without advance notice.