

QLD106L-6430C series

1064 nm/30 mW DFB Laser Butterfly Package

C00232-01 June 2020



1. DESCRIPTION

The QLD106L-6430C series is a 1064-nm distributed feedback (DFB) laser for use in seeder for fiber lasers and sensing applications. The laser is assembled into a 14-pin butterfly package with a monitor PD and a thermo-electric cooler.

2. FEATURES

- Single longitudinal mode operation at 1064 nm
- Fiber-pigtailed 14-pin butterfly package with a monitor PD and a TEC
- Without an optical isolator and with one polarizer
- Polarization maintaining fiber integration
- CW operation

3. APPLICATIONS

- Seeder for fiber lasers
- Sensing

4. ABSOLUTE MAXIMUM RATINGS

PARAMETER	SYMBOL	RATING	UNIT
Optical Output power	P_f	50	mW
LD Forward Current	I_F	250	mA
LD Reverse Voltage	V_{RLD}	2	V
TEC Drive Current	I_{TEC}	2	A
TEC Drive Voltage	V_{TEC}	4.3	V
LD Chip Temperature	T_{Chip}	10 to 40	°C
Operation Temperature	T_c	0 to 60	°C
Storage Temperature	T_{stg}	-40 to 85	°C
Lead Soldering Temperature (5 s)	T_{sld}	230	°C

Distributed by  **imm photonics**

Ohmstrasse 4, 85716 Unterschleissheim, Germany

www.imm-photonics.de sales@imm-photonics.de Tel.: +49 89 / 3214120

5. OPTICAL AND ELECTRICAL CHARACTERISTICS

 (T_{LD} = 25°C, unless otherwise specified)

PARAMETER	SYMBOL	TEST CONDITION	MIN	TYP	MAX	UNIT
Peak Wavelength	λ_p	CW, P _f =30 mW	1059*	1064	1069*	nm
Spectral Linewidth (FWHM)	$\Delta\lambda$	CW, P _f =30 mW	-	10**	-	MHz
Temperature Coefficient of λ_p	$d\lambda_p/dT$	CW	-	0.08	-	nm/K
Current Coefficient of λ_p	$d\lambda_p/dI$	CW	-	0.008	-	nm/mA
Fiber Output Power	P _f	CW	30	-	-	mW
Threshold Current	I _{th}	CW	-	15	-	mA
Operation Current	I _{op}	CW, P _f =30 mW	-	90	140	mA
Operation Voltage	V _{op}	CW, P _f =30 mW	-	1.5	1.8	V
Sidemode Suppression Ratio	SMSR	CW, P _f =30 mW	30	40	-	dB
Polarization Extinction Ratio	PER	CW	15	20	-	dB
Monitor PD Current	I _m	CW, P _f =30mW	50	200	800	μA
Thermistor Resistance	R _{th}	T _{LD} = 25°C, B=3900K	9.5	10	10.5	kΩ

*Peak wavelength tolerance of +/- 1 nm is available as an option.

**The spectral linewidth under CW operation is about 10 MHz, but QD Laser cannot guarantee the value because it strongly depends on measurement conditions including drivers for operations.

6. PRODUCT PART NUMBER

Part Number	Fiber Type	Fiber Diameter	Connector
QLD106L-6430C	Polarization maintaining fiber	900um	FC/APC
QLD106L-6430C-11		250um	Ferrule

7. OUTLINE DRAWING

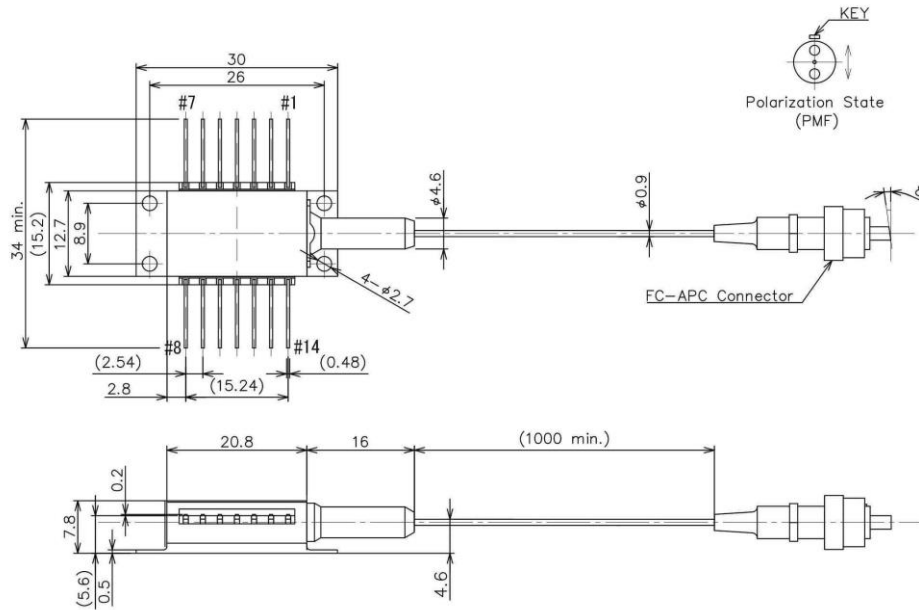

(a) 900um fiber diameter and FC/APC connector type (QLD106L-6430C)

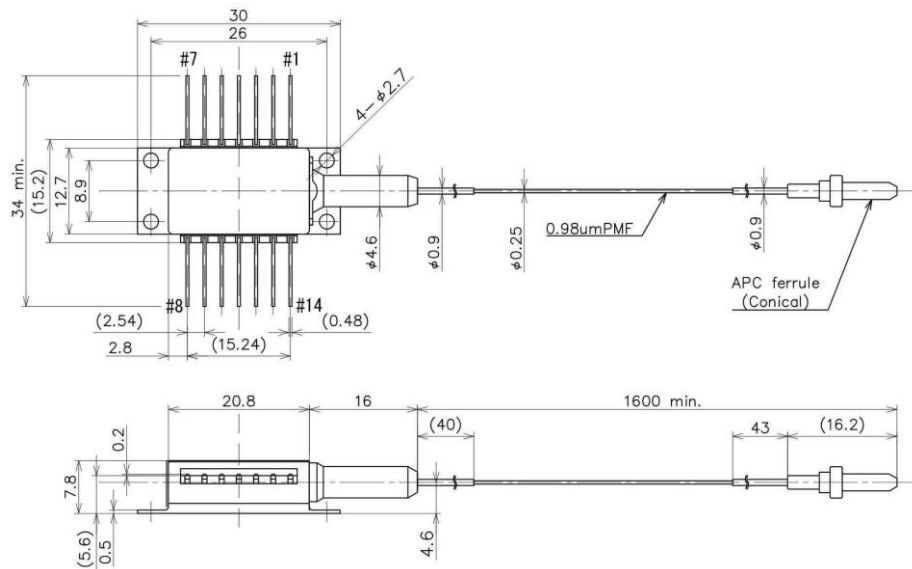

(b) 250um fiber diameter and ferrule type (QLD106L-6430C-11)

8. PIN CONFIGURATION

No.	Description	No.	Description
1	TEC (+)	8	NC
2	Thermistor	9	NC
3	PD Anode	10	Laser Anode
4	PD Cathode	11	Laser Cathode
5	Thermistor	12	NC
6	NC	13	Case Ground
7	NC	14	TEC (-)

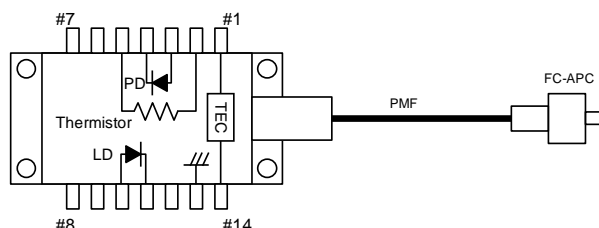

9. NOTICE

- Safety Information

This product is classified as Class 3B laser product, and complies with 21 CFR Part 1040.10.

Please do not take a look at laser lighting in operations since laser devices may cause troubles to human eyes.

Please do not eat, burn, break and make chemical process of the products since they contain GaAs material.

- Handling products

Semiconductor lasers are easily damaged by external stress such as excess temperature and ESD.

Please pay attention to handling products, and use within range of maximum ratings.

QD Laser takes no responsibility for any failure or unusual operation resulting from improper handling, or unusual physical or electrical stress.

- RoHS

This product conforms to RoHS compliance related Directive (EU) 2015/863.

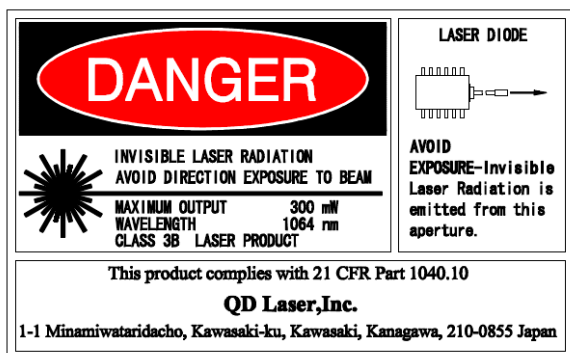

Distributed by  imm photonics

Ohmstrasse 4, 85716 Unterschleissheim, Germany

www.imm-photonics.de sales@imm-photonics.de Tel.: +49 89 / 3214120

QD Laser, Inc.

Contact : info@qdlaser.com <https://www.qdlaser.com>

Copyright 2020 All Rights Reserved by QD Laser, Inc.

Keihin Bldg. 1F 1-1 Minamiwatarida-cho, Kawasaki-ku, Kawasaki, Kanagawa Zip 210-0855 Japan

All company or product names mentioned herein are trademarks or registered trademarks of their respective owners. Information provided in this data sheet is accurate at time of publication and is subject to change without advance notice.