

iC-LSHB

INCREMENTAL PHOTODIODE ARRAY



Rev E1, Page 1/10

FEATURES

- ◆ Monolithic array of independent photodiodes with excellent matching
- ◆ Compact photodiode size of 800 μm x 330 μm enabling smaller encoder systems
- ◆ Moderate track pitch for reasonable alignment tolerances
- ◆ Ultra low dark currents for operation to high temperature
- ◆ Low noise amplifiers with high transimpedance of typ. 1 MΩ
- ◆ Short-circuit-proof, low impedance voltage outputs for enhanced EMI tolerance
- ◆ Space saving optoBGA and optoQFN package (RoHS compliant)
- ◆ Low power consumption from single 4.1 V to 5.5 V supply
- ◆ Operational temperature range of -40 °C to +125 °C
- ◆ Available options
 - reticle assembly, code discs
 - customized COB modules

APPLICATIONS

- ◆ Incremental rotary encoders
- ◆ Linear scales

PACKAGES

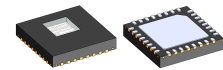

32-pin optoQFN
5 mm x 5 mm x 0.9 mm
RoHS compliant

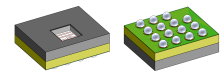

15-pin optoBGA
6.2 mm x 5.2 mm
RoHS compliant

BLOCK DIAGRAM

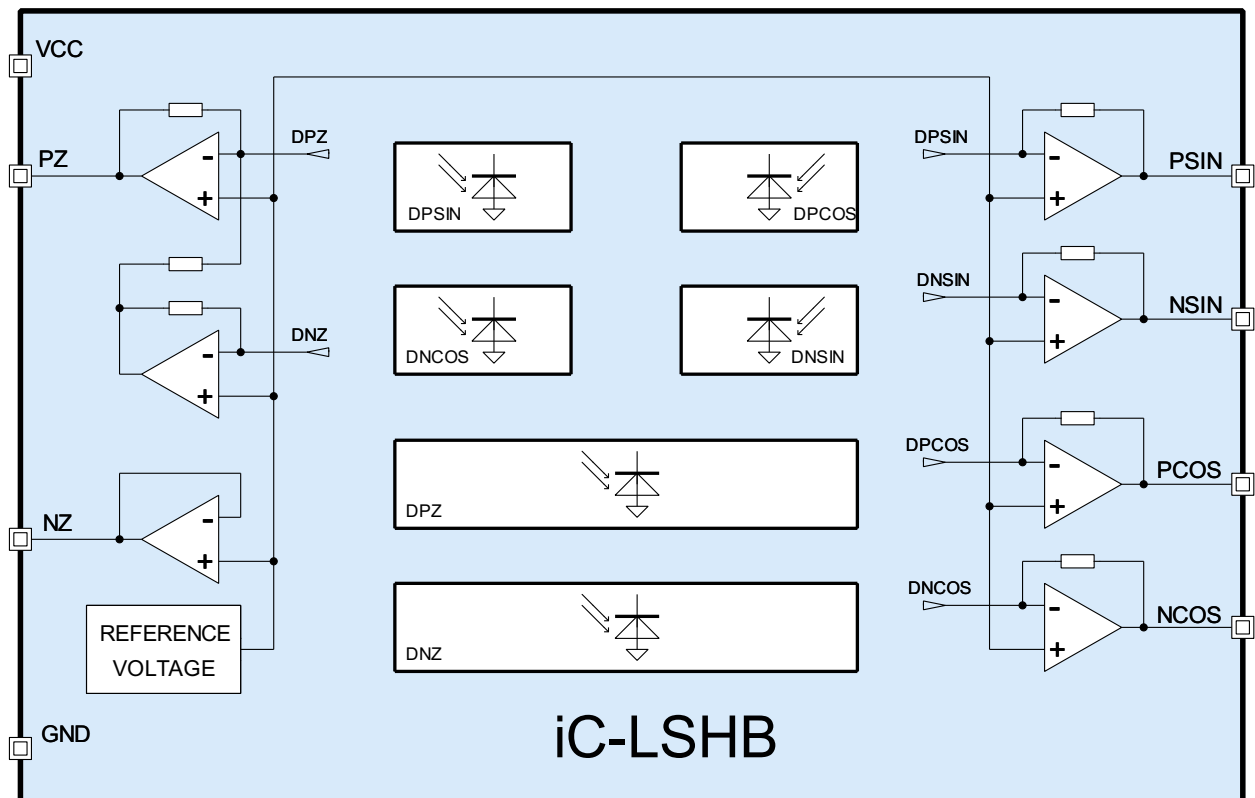

iC-LSHB

INCREMENTAL PHOTODIODE SENSOR ARRAY



Rev E1, Page 2/10

DESCRIPTION

iC-LSHB is an optical sensor IC with 6 integrated photodiodes whose signal currents are converted into output voltages by low-noise transimpedance amplifiers.

The IC is well suited for the operation of interpolation circuits for linear or rotary incremental encoders with an index signal. iC-LSHB thus has a shamrock-style sensor layout of four photodiodes, each with an active area of $800\ \mu\text{m} \times 330\ \mu\text{m}$. Both a positive and negative sine signal and a positive and negative cosine signal are generated from a single shared code track. The signal amplifier layout ensures excellent paired channel matching, reducing signal differences to an absolute minimum.

Two separate photodiodes, with active areas of $1720\ \mu\text{m} \times 150\ \mu\text{m}$ apiece, are employed for the differential scanning of the index track and to generate the zero signal.

The spectral sensitivity ranges from visible to near infrared light, with the maximum sensitivity close to a wavelength of 680 nm.

A high transimpedance gain of typically $1\ \text{M}\Omega$ generates output signals of a few hundred Millivolts already from illumination levels of $0.8\ \text{mW}/\text{cm}^2$.

A threefold intensity is sufficient when using iC-LSHB for encoder applications with typical disc and mask codes. Therefore, a relatively low LED current is enough to operate the sensor, proving beneficial to the life expectancy of the LED at high operating temperatures.

iC-LSHB is suitable for on-chip or LED-end mounting of the grating (reticle), so that the period count, signal waveform, phase shift and index marker code can be selected with flexibility.

PACKAGING INFORMATION

PAD LAYOUT (2.88 mm x 2.04 mm)

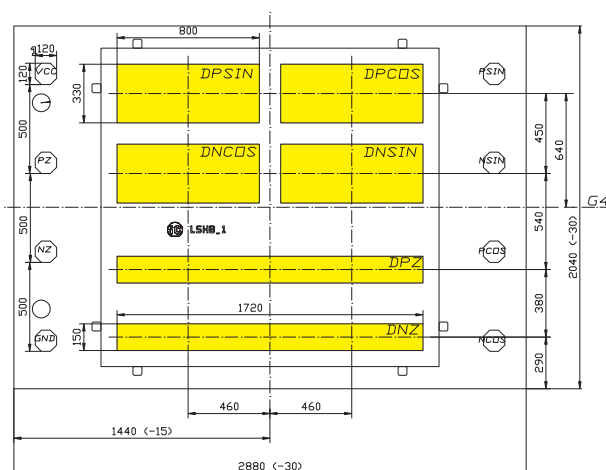

PAD FUNCTIONS

No. Name Function

Refer to the description of pin functions.

Note: Dimension G4 is the reference radius of the chip center.

iC-LSHB

INCREMENTAL PHOTODIODE ARRAY



Rev E1, Page 3/10

PIN CONFIGURATION

oBGA LSH2C (6.2 mm x 5.2 mm)

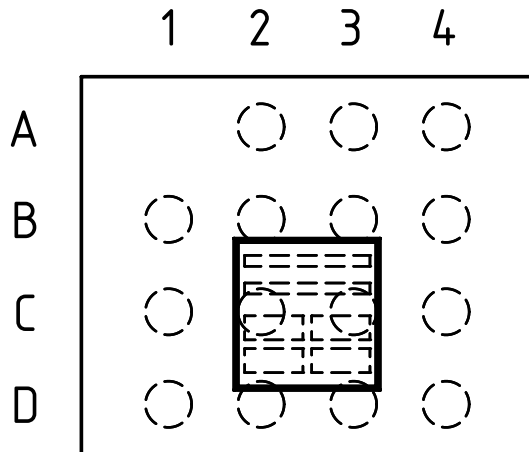

PIN FUNCTIONS

No.	Name	Function
A2	n.c. ¹	
A3	n.c.	
A4	n.c.	
B1	n.c.	
B2	n.c.	
B3	n.c.	
B4	n.c.	
C1	NCOS	Cosine -
C2	PCOS	Cosine +
C3	NZ	Reference Voltage Output
C4	GND	Ground
D1	NSIN	Sine -
D2	PSIN	Sine +
D3	VCC	+4.1...5.5 V Supply Voltage
D4	PZ	Zero Signal (Index)

NB: All outputs supply analog voltages.

For dimensional specifications refer to the relevant package data sheet, available separately.

PIN CONFIGURATION

oQFN32-5x5 (5 mm x 5 mm)

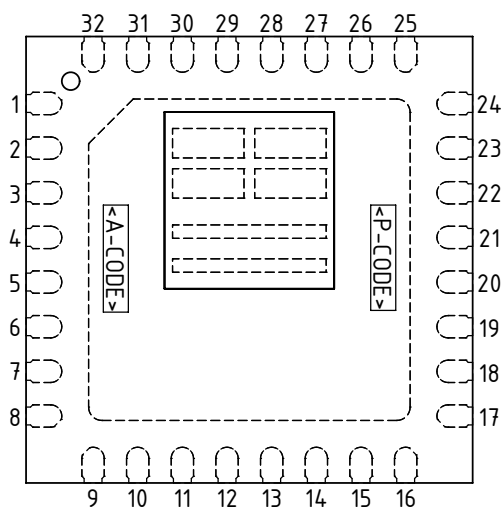

PIN FUNCTIONS

No.	Name	Function
1	n.c. ¹	
2	VCC	+4.1...5.5 V Supply Voltage
3	PZ	Zero Signal (Index)
4	NZ	Reference Voltage Output
5	GND	Ground
6-19	n.c.	
20	NCOS	Cosine -
21	PCOS	Cosine +
22	NSIN	Sine -
23	PSIN	Sine +
24-32	n.c.	
	BP ²	Backside paddle

NB: All outputs supply analog voltages.

IC top marking: <P-CODE> = product code, <A-CODE> = assembly code (subject to changes);

¹ Pin numbers marked n.c. are not connected.

² Connecting the backside paddle is recommended by a single link to GND (use as shield). A current flow across the paddle is not permissible.

PACKAGE DIMENSIONS oQFN32-5x5

RECOMMENDED PCB-FOOTPRINT

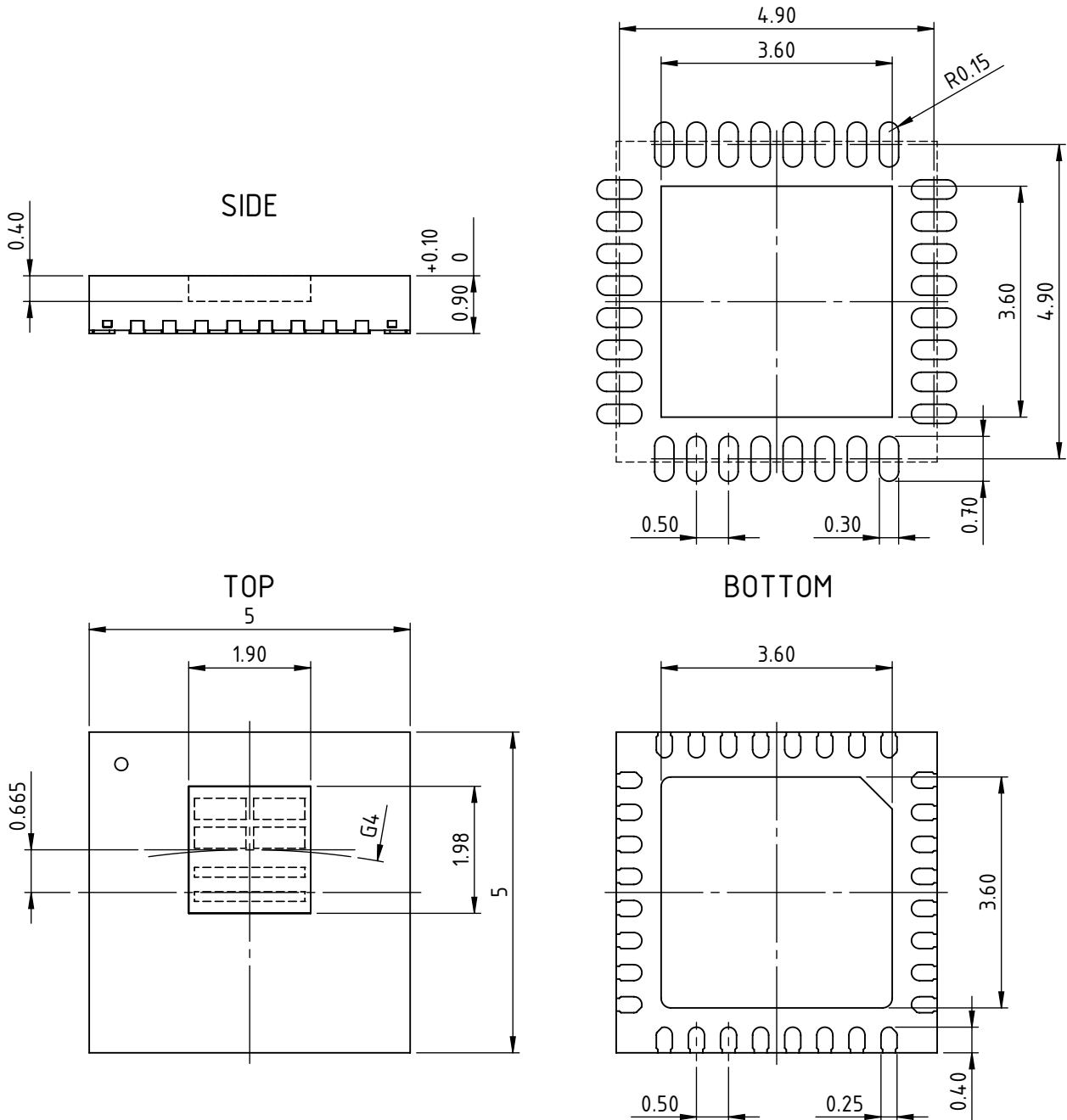

All dimensions given in mm. General Tolerances of form and position according to JEDEC MO-220.
 Positional tolerance of sensor pattern: $\pm 70\mu\text{m}$ / $\pm 1^\circ$ (with respect to center of backside pad).
 G4: radius of chip center (refer to the relevant encoder disc and code description).
 Maximum molding excess $+20\mu\text{m}$ / $-75\mu\text{m}$ versus surface of glass. Small pits in the mold surface, which may occasionally appear due to the manufacturing process, are cosmetic in nature and do not affect reliability.

iC-LSHB

INCREMENTAL PHOTODIODE ARRAY



Rev E1, Page 5/10

ABSOLUTE MAXIMUM RATINGS

These ratings do not imply operating conditions; functional operation is not guaranteed. Beyond these ratings device damage may occur.

Item No.	Symbol	Parameter	Conditions			Unit
				Min.	Max.	
G001	VCC	Voltage at VCC		-0.3	6	V
G002	I(VCC)	Current in VCC		-20	20	mA
G003	V()	Pin Voltage, all signal outputs		-0.3	VCC + 0.3	V
G004	I()	Pin Current, all signal outputs		-20	20	mA
G005	Vd()	ESD Susceptibility, all pins	HBM, 100 pF discharged through 1.5 kΩ		2	kV
G006	Tj	Junction Temperature		-40	150	°C
G007	Ts	Chip Storage Temperature		-40	150	°C

THERMAL DATA

Operating conditions: VCC = 4.1 V ... 5.5 V

Item No.	Symbol	Parameter	Conditions	Min.	Typ.	Max.	Unit
T01	Ta	Operating Ambient Temperature Range	package oQFN32-5x5	-40		125	°C
			package oBGA LSH2C	-40		110	°C
T02	Ts	Storage Temperature Range	package oQFN32-5x5	-40		125	°C
			package oBGA LSH2C	-40		110	°C
T03	Tpk	Soldering Peak Temperature	package oQFN32-5x5;				
			tpk < 20 s, convection reflow tpk < 20 s, vapor phase soldering MSL 5A (max. floor life 24 h at 30 °C and 60 % RH); Refer to Handling and Soldering Conditions for details.			245 230	°C °C
T04	Tpk	Soldering Peak Temperature	package oBGA LSH2C				
			tpk < 20 s, convection reflow tpk < 20 s, vapor phase soldering TOL (time on label) 8 h; Refer to Handling and Soldering Conditions for details.			245 230	°C °C

All voltages are referenced to ground unless otherwise stated.

All currents flowing into the device pins are positive; all currents flowing out of the device pins are negative.

iC-LSHB

INCREMENTAL PHOTSENSOR ARRAY



Rev E1, Page 6/10

ELECTRICAL CHARACTERISTICS

Operating conditions: VCC = 4.1..5.5 V, Tj = -40..125 °C, unless otherwise stated

Item No.	Symbol	Parameter	Conditions				Unit
				Min.	Typ.	Max.	
Total Device							
001	VCC	Permissible Supply Voltage		4.1		5.5	V
002	I(VCC)	Supply Current in VCC	no output load, photocurrents within linear operating range (no override)		6.5	12	mA
003	Vc()hi	Clamp-Voltage hi at all pins	I() = 4 mA			11	V
004	Vc()lo	Clamp-Voltage lo at all pins	I() = -4 mA	-1.2		-0.3	V
Photosensors							
101	λ_{ar}	Spectral Application Range	$Se(\lambda_{ar}) = 0.25 \times S(\lambda_{pk})$	400		950	nm
102	λ_{pk}	Peak Sensitivity Wavelength			680		nm
103	Aph()	Radiant Sensitive Area of DPSIN, DPCOS, DNSIN, DNCOS	0.8 mm x 0.33 mm		0.264		mm ²
104	Aph()	Radiant Sensitive Area of DPZ, DNZ	1.72 mm x 0.15 mm		0.258		mm ²
105	S(λ_r)	Spectral Sensitivity	$\lambda_{LED} = 460$ nm $\lambda_{LED} = 740$ nm $\lambda_{LED} = 850$ nm		0.25 0.5 0.35		A/W A/W A/W
107	E()mx	Irradiance For Maximum Signal Level	$\lambda_{LED} = 740$ nm, Vout() not yet saturated		1.7		mW/cm ²
Photocurrent Amplifiers							
201	Iph()	Permissible Photocurrent Operating Range		0		1120	nA
202	$\eta()$ r	Photo Sensitivity (light-to-voltage conversion ratio)	$\lambda_{LED} = 740$ nm	0.2	0.3	0.5	V/ μ W
203	Z()	Equivalent Transimpedance Gain	$Z = Vout() / Iph()$	0.7	1.0	1.4	M Ω
204	TCz	Temperature Coefficient of Transimpedance Gain			-0.12		%/°C
209	$\Delta Z()$ pn	Transimpedance Gain Matching Of Paired Amplifiers	P.. channel vs. corresponding N.. channel	-0.2		0.2	%
210	$\Delta Vout()$ pn	Signal Matching	no illumination, any output vs. any output	-35		35	mV
211	$\Delta Vout()$ pn	Signal Matching	no illumination, P.. output vs. corresponding N.. output	-2.5		2.5	mV
212	fc()hi	Cut-off Frequency (-3 dB)			400		kHz
213	VNoise()	RMS Output Noise	illuminated to 500 mV signal level above dark level, 500 kHz band width		0.5		mV
Signal Outputs PSIN, NSIN, PCOS, NCOS, PZ							
301	Vout()mx	Permissible Maximum Output Voltage	illumination to E()mxr, linear gain; VCC = 4.5...5.5 V VCC = 4.1 V	2.4 2.0			V V
302	Iout()mx	Permissible Max. Load Current		-100		250	μ A
303	Vout()d	Dark Signal Level	no illumination, load 20 k Ω vs. +2 V	575	770	1000	mV
305	Isc()hi	Short-circuit Current hi	load current to ground	100	420	1300	μ A
306	Isc()lo	Short-circuit Current lo	load current to IC	250	480	700	μ A
307	Ri()	Internal Output Resistance	f = 1 kHz	70	110	180	Ω
308	ton()	Power-On Settling Time	VCC = 0 V \rightarrow 5 V			100	μ s
Reference Voltage NZ							
401	VREF	Reference Voltage	I(VREF) = -100...+300 μ A	575	770	1000	mV
402	dVout()	Load Balancing	I(VREF) = -100...+300 μ A	-10		+10	mV
403	Isc()hi	Short-circuit Current hi	load current to ground	200	420	2000	μ A
404	Isc()lo	Short-circuit Current lo	load current to IC	0.4	4.5	10	mA

APPLICATION HINTS

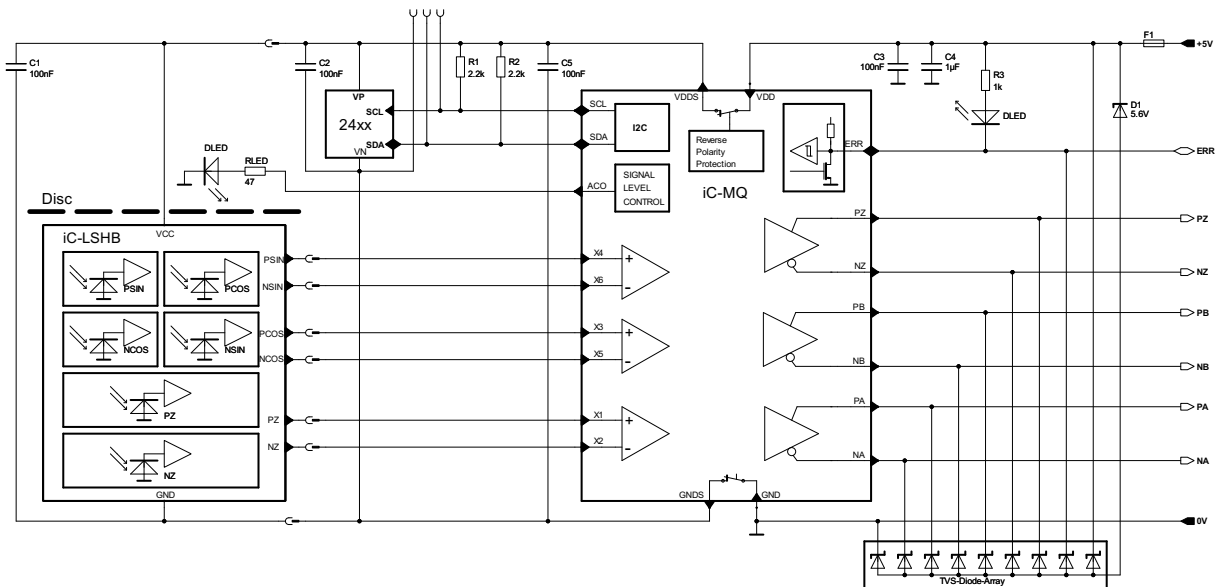

Figure 1: Example of incremental encoder with RS422 output

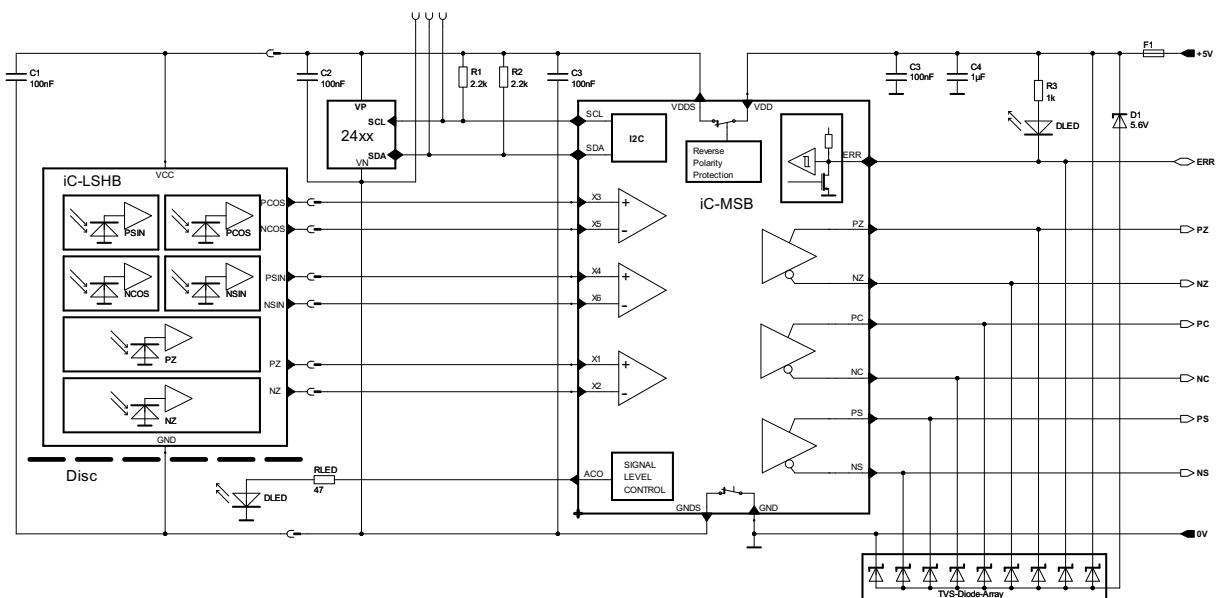

Figure 2: Example of sine encoder with 1 Vpp output

DESIGN REVIEW: Notes On Chip Functions

iC-LSHB 2		
No.	Function, Parameter/Code	Description and Application Hints
1		Please refer to former datasheet release B1.

Table 1: Notes on chip functions regarding iC-LSHB chip release 2.

iC-LSHB Z, Z1, Z2		
No.	Function, Parameter/Code	Description and Application Hints
1		No further notes at time of printing.

Table 2: Notes on chip functions regarding iC-LSHB chip release Z, Z1, Z2.

REVISION HISTORY

Rel.	Rel. Date ¹	Chapter	Modification	Page
D1	2017-08-04	FEATURES	Preliminary label removed Supply voltage extended to include 4.1 V Operational temperature up to 125 °C	1
		PACKAGING INFORMATION	oQFN with top marking, revision of footnote, update of oQFN package drawing	3, 4
		THERMAL DATA	Operating temperature up to 125 °C for oQFN	5
		ELECTRICAL CHARACTERISTICS	Operating conditions: VCC supply voltage extended to include 4.1 V Item 001: min. limit; item 101, condition: reference to λ_{pk} Item 105: 460 nm supplemented Items 301, 303: conditions and limits (4.1 V added), item 302: new item, item 304: removed, item 401: min. limit, item 403: max. limit	6
		DESIGN REVIEW	Chip release Z1 supplemented.	8
		ORDERING INFORMATION	Listing updated	9

Rel.	Rel. Date ¹	Chapter	Modification	Page
D2	2018-10-10	PACKAGING INFORMATION	Package LSH2C: correction of pin functions	3
		ELECTRICAL CHARACT.	Item 105: limits adapted	6

Rel.	Rel. Date ¹	Chapter	Modification	Page
D3	2021-05-12	PACKAGING INFORMATION, PACKAGE DIMENSIONS	Update of package drawings and footnotes	3, 4
		THERMAL DATA	Item T03, T04: hyperlink to customer information	5

Rel.	Rel. Date ¹	Chapter	Modification	Page
E1	2022-03-30	DESIGN REVIEW	Chip release Z2 supplemented.	8
		ELECTRICAL CHARACT.	Items 305, 403: max limit	6

¹ Release Date format: YYYY-MM-DD

iC-LSHB

INCREMENTAL PHOTODIODE ARRAY



Rev E1, Page 9/10

iC-Haus expressly reserves the right to change its products, specifications and related supplements (together the Documents). A Datasheet Update Notification (DUN) gives details as to any amendments and additions made to the relevant Documents on our internet website www.ichaus.com/DUN and is automatically generated and shall be sent to registered users by email. Copying – even as an excerpt – is only permitted with iC-Haus' approval in writing and precise reference to source.

The data and predicted functionality is intended solely for the purpose of product description and shall represent the usual quality and behaviour of the product. In case the Documents contain obvious mistakes e.g. in writing or calculation, iC-Haus reserves the right to correct the Documents and no liability arises insofar that the Documents were from a third party view obviously not reliable. There shall be no claims based on defects as to quality and behaviour in cases of insignificant deviations from the Documents or in case of only minor impairment of usability. No representations or warranties, either expressed or implied, of merchantability, fitness for a particular purpose or of any other nature are made hereunder with respect to information/specification resp. Documents or the products to which information refers and no guarantee with respect to compliance to the intended use is given. In particular, this also applies to the stated possible applications or areas of applications of the product.

iC-Haus products are not designed for and must not be used in connection with any applications where the failure of such products would reasonably be expected to result in significant personal injury or death (*Safety-Critical Applications*) without iC-Haus' specific written consent. Safety-Critical Applications include, without limitation, life support devices and systems. iC-Haus products are not designed nor intended for use in military or aerospace applications or environments or in automotive applications unless specifically designated for such use by iC-Haus. iC-Haus conveys no patent, copyright, mask work right or other trade mark right to this product. iC-Haus assumes no liability for any patent and/or other trade mark rights of a third party resulting from processing or handling of the product and/or any other use of the product.

Software and its documentation is provided by iC-Haus GmbH or contributors "AS IS" and is subject to the ZVEI General Conditions for the Supply of Products and Services with iC-Haus amendments and the ZVEI Software clause with iC-Haus amendments (www.ichaus.com/EULA).

iC-LSHB

INCREMENTAL PHOTSENSOR ARRAY



Rev E1, Page 10/10

ORDERING INFORMATION

Type	Package	Options	Order Designation
iC-LSHB	15-pin optoBGA, 6.2 mm x 5.2 mm, thickness 1.7 mm RoHS compliant	glass lid	iC-LSHB OBGA LSH2C
		reticle LSHB2R 42-1024	iC-LSHB OBGA LSH2C-2R
		reticle LSHB4R 42-4096	iC-LSHB OBGA LSH2C-4R
		reticle LSHB5R 26-3600 custom reticle	iC-LSHB OBGA LSH2C-5R iC-LSHB OBGA LSH2C-xxR
iC-LSHB	32-pin optoQFN, 5 mm x 5 mm, thickness 0.9 mm RoHS compliant	glass lid	iC-LSHB oQFN32-5x5
		reticle LSHB2R 42-1024	iC-LSHB oQFN32-5x5-2R
		custom reticle	iC-LSHB oQFN32-5x5-xxR
Code Discs		1024 CPR OD \varnothing 42 mm, ID \varnothing 18 mm (glass 1 mm)	LSHB2S 42-1024
		4096 CPR OD \varnothing 42 mm, ID \varnothing 18 mm (glass 1 mm)	LSHB4S 42-4096
		3600 CPR OD \varnothing 26 mm, ID \varnothing 14 mm (glass 1 mm)	LSHB5S 26-3600

Please send your purchase orders to our order handling team:

Fax: +49 (0) 61 35 - 92 92 - 692

E-Mail: dispo@ichaus.com

For technical support, information about prices and terms of delivery please contact:

iC-Haus GmbH
Am Kuemmerling 18
D-55294 Bodenheim
GERMANY

Tel.: +49 (0) 61 35 - 92 92 - 0
Fax: +49 (0) 61 35 - 92 92 - 192
Web: <http://www.ichaus.com>
E-Mail: sales@ichaus.com

Appointed local distributors: http://www.ichaus.com/sales_partners