

DESCRIPTION

This is a high radiance 584 nm Yellow LED optimized for applications requiring high reliability visible indicators.

ABSOLUTE MAXIMUM RATINGS

- Storage temperature..... -65°C to +125°C
- Case operating temperature -65°C to +125°C
- Lead solder temperature.... 260°C, 10 seconds
- Continuous forward current..... 35 mA
- Peak Forward Current..... 1 A $\sqrt{1}$
- Reverse Voltage..... 5 Volts

$\sqrt{1}$ 1 μsec pulse width, 300 Hz

OUTLINE DIMENSIONS

Tolerances are +/-0.005 inches, except as noted

Pinout

- 1. Cathode 2. Anode

The case is electrically isolated from the pins.

ELECTRO-OPTICAL CHARACTERISTICS (Case T = 25°C)

PARAMETER	TEST CONDITION	SYMBOL	MIN	TYP	MAX	UNIT
Forward Voltage	If = 20 mA	V _f		2.3	3.0	Volts
Reverse Current	V _r = 3V	I _r			1.0	μA
Half Angle at Half Power		θ _{1/2}		12		DEG
Capacitance	V _r = 0 V, f = 1 MHz	C			100	pF
Luminous Intensity 1	If = 20 mA, 0 degrees	I _{v1}	3	20		mcd
Luminous Intensity 2	If = 20 mA, 30 degrees	I _{v2}	1.5			mcd
Peak Wavelength	If = 20 mA	λ _p	550	584	660	nm

FEATURES

- 584 nm Yellow
- High luminous intensity, 20 mcd typical
- High Reliability
- Hermetic Package
- 30 Degree Half angle of light emission
- Meets 1N6093 specification
- Available screened to MIL-PRF-19500/520

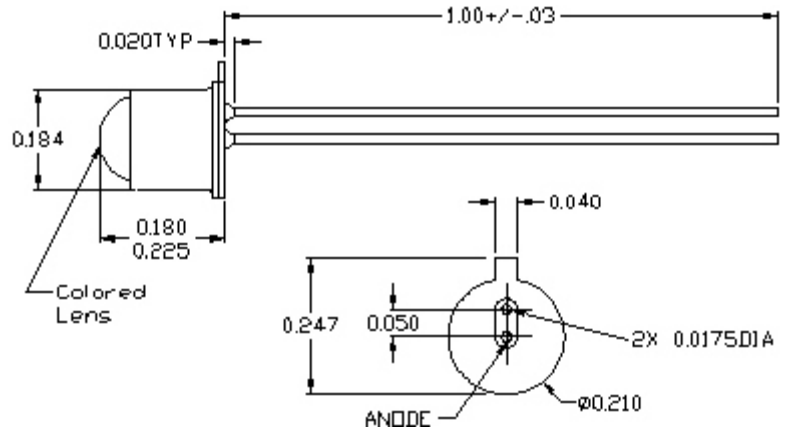

distributed by